

Natural gas  
Propane Gas  
Class D oil  
Dual fuel

163 kW  
to  
355 kW

## CKON

Cast iron boiler



- **Seasonal efficiency of over 84% gives compliance with ADLB2 2010 for gas-fired boilers without the need for additional heating credits**
- **Compact heat exchanger gives small footprint relative to output**
- **Delivered in loose sections for easy site access**
- **Wide range of 2-stage gas and oil, dual-fuel and modulating gas burners available**

Contents	Page
General information	2
Dimensions & data	3
Installation requirements	4 - 6
Boiler control & wiring	6 & 7

## General information

---

### Description

CKON cast iron sectional boilers are designed for use in either open vented or pressurised heating systems up to 6 bar working pressure with gas, oil or dual fuel burners. There are seven models in the range 163 kW to 355 kW. The boiler has a pressurised combustion chamber and burners offered by Clyde are all capable of overcoming the boiler resistance without the assistance of the chimney.

These are 3-pass boilers and comply with the efficiency requirements of ADL2: 2010 of The Building Regulations.

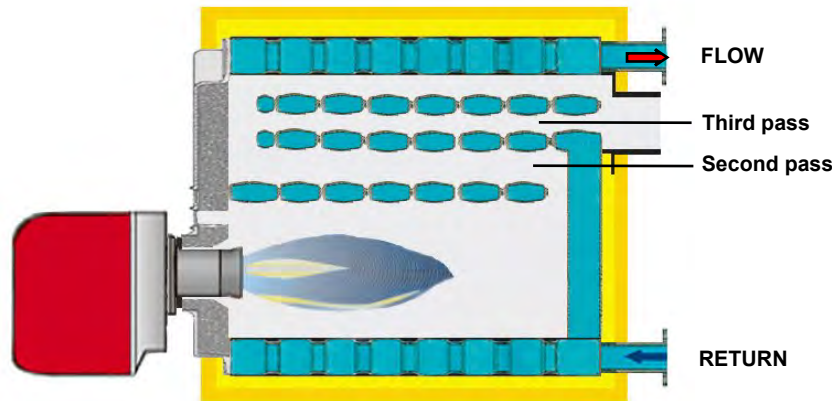

Fig 1 3-pass operation of boiler

---

### Application

CKON boilers are made from Grade GG20 cast iron and conform with the requirements of EN 303. The boilers are suitable for use in LTHW heating systems with a maximum operating pressure of 6 bar and maximum temperature of 90°C.

CKON boilers may be fired by Natural gas, LPG, Class D or Class C oil with 1 or 2-stage control.

The boiler is suitable for use in either open vented or pressurised heating systems. It is not suitable for use as a direct water heater. Where potable water is required, a matching calorifier or plate heat exchanger must be provided in the system.

### Statutory requirements

CKON boilers are CE marked and must be fired by a compatible burner certified to EN267 (oil firing) or EN676 (gas firing) to comply with the Boiler (Efficiency) Directive 1993.

The installation, assembling and commissioning of the boiler must be carried out by a qualified engineer in accordance with the instructions provided.

Gas supplies and gas burners must be installed and commissioned by a qualified person, eg. a Gas Safe registered engineer.

---

### Materials & boiler assembling

The boiler is supplied as loose cast iron sections for assembly on site. Each section is tested hydraulically for soundness in accordance with EN303. The assembled boiler should also be hydraulically tested on site in accordance with this standard and a test certificate issued. Insulation, steel jacket, boiler control panel and burner are packed separately for fitting on site.

Site assembling should only be undertaken by Clyde or their authorised engineer. All insulating and refractory materials are included, with ceramic sealing ropes for all access doors.

### Handling

Offloading, dry storing and placing of equipment in the boiler room is the responsibility of the installer.

Equipment must be dry stored and protected from frost. Cartons must not be crushed or otherwise damaged.

### Commissioning

Clyde undertake commissioning of boilers. Commissioning

charges do not include servicing during the guarantee period. This may be carried out under service contract or to specific order.

### Boiler log book

A boiler log book that provides a permanent record of commissioning and servicing data and measurements is supplied with every boiler. It should be kept safe and updated whenever routine or emergency work is performed on the boiler.

### Guarantee

Subject to correct handling, installation and operation, all equipment is guaranteed for twelve months from the date of despatch. Boiler sections are guaranteed for a period of five years from the date of despatch.

The guarantee is not valid if the boiler is subjected to thermal stress, becomes blocked with debris and/or carbonate deposits from the system water and/or there is no documented evidence of commissioning by a competent engineer.

## Dimensions and technical data

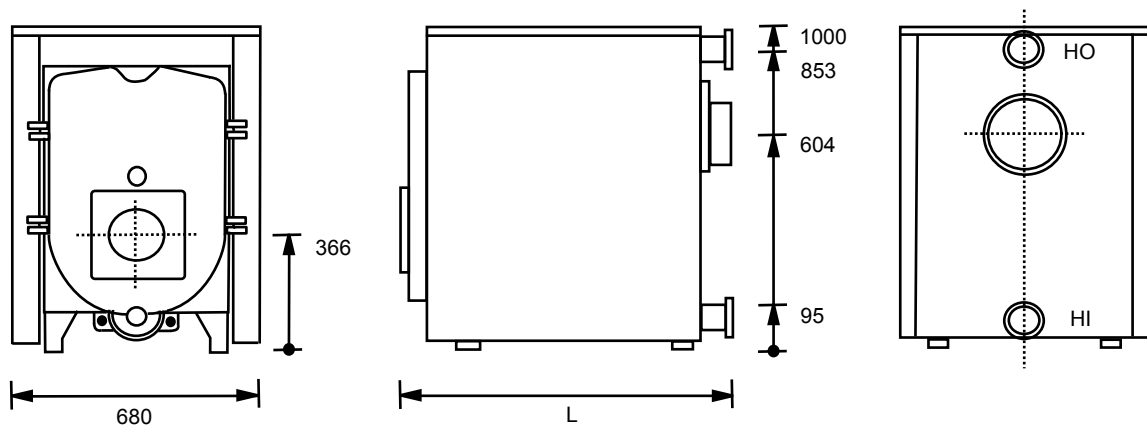

### Dimensions

Boiler model		CKON-05	CKON-06	CKON-07	CKON-08	CKON-09	CKON-10	CKON-11	
Output	kW	163	195	227	259	291	323	355	
No. sections		5	6	7	8	9	10	11	
Overall length	L mm	1070	1215	1360	1505	1650	1795	1940	
Combustion chamber length	mm	691	835	979	1123	1267	1411	1555	
Combustion chamber dimensions	mm	442 W x 391 H							
Boiler door thickness	mm	145							
Boiler flow connection	HO	DN80							
Boiler return connection	HI	DN80							
Flue spigot diameter	mm	180			250				

### Technical data

Nominal heat output (full load) ncv	kW	162.8	194.8	226.7	258.7	290.7	322.7	354.7
Nominal heat input (full load) ncv	kW	176.6	211.4	246.2	280.8	315.9	350.9	385
Efficiency at 100% load (ncv)	%	92.2	92.1	92.1	92.1	92	92	92.1
Efficiency at 30% load (ncv)	%	95.2	95.2	95.1	95.2	95.1	95	95.2
Boiler seasonal efficiency(1)	%	85.3	85.2	85.2	85.2	85.1	85.1	85.2
Natural gas consumption (gcv)	m <sup>3</sup> /h	18.3	21.9	25.5	29.1	32.7	36.4	39.9
Oil consumption class D (ncv)	kg/h	15.1	18.1	21.1	24	27	30	32.9
Dry weight (excludes burner)	kg	483	560	636	715	792	869	947
Water volume	litres	77	93	109	125	141	157	173
Flue gas mass flow @3% oxygen	m <sup>3</sup> /h	18.2	21.8	25.4	28.9	32.5	36.1	39.7
Chimney draught	Pa	5						
Gas side resistance	mbar	1.6	1.7	1.9	2.2	2.5	2.8	3.1
Flue gas temperature rise @3% oxygen	Nat gas (2) °C	164	163	160	159	155	153	152
	Class D oil °C	187	185	182	181	180	180	179
Maximum working temperature	°C	90						
Maximum hydraulic working pressure	bar	6						
CE-Registration number		CE 1015BR0261						

### Water flow rates and hydraulic resistances

Water flow rate at 11°C temp. rise	l/s	3.52	4.22	4.9	5.6	6.29	6.98	7.68
Hydraulic resistance at 11°C temp. rise	kPa	3.2	4.3	5.9	8.6	9.34	11.6	14.14
Water flow rate at 20°C temp. rise	l/s	1.94	2.32	2.7	3.08	3.46	3.84	4.22
Hydraulic resistance at 20°C temp. rise	kPa	1.5	1.75	2.3	2.5	2.6	3.1	4.1
Water flow rate at 30°C temp. rise	l/s	1.29	1.55	1.8	2.05	2.3	2.56	2.82
Hydraulic resistance at 30°C temp. rise	kPa	0.71	0.9	1.12	1.3	1.56	1.7	1.9

Notes: (1) Calculated from the non-domestic heating and cooling compliance guide for conformance with ADL2A and

ADL2B 2010 using the formula  $n_{\text{seasonal}} = 0.81n_{30\%} + 0.19n_{100\%}$

(2) BS 7190:1989

## Installation requirements

### Boiler location (Refer Figs 2 & 3)

The location chosen for the boiler(s) must be frost free, provide for a satisfactory flue system and an adequate air supply for combustion and ventilation. Adequate access is necessary for boiler and burner servicing.

Boilers must not be installed in areas where flammable vapours are likely to be present. To avoid damage to the boilers, contamination of the combustion air by high levels of dust or halogenated hydrocarbons (eg. Solvents, spray can propellants, cleaning agents, adhesives, etc) must be avoided.

Boilers should be installed on a plinth which is at least 50mm high and is smooth and level (NB : for some burners with acoustic shrouds the plinth may need to be higher - refer Clyde Sales Office).

An uneven plinth can inhibit freedom for expansion and contraction of the boiler during operation.

### Burners

Boilers can be supplied with one or two stage Natural gas, LPG, Class D or Class C oil burners. A choice of burner makes is available.

### Fuel specification

Natural gas (GCV 38.76 MJ/m<sup>3</sup>) with a minimum gas inlet pressure according to the burner model specified.

BS2869 Class D oil (35 sec). Advice should be sought from the oil supplier regarding the storage of Class D oil.

### Fuel supply pipework

Install gas or oil supply pipe(s) and service valve(s) so as to allow free access to the boiler and full opening of the furnace door without removing the burner from the boiler door (see below).

Commissioning of the gas supply pipework and components must be carried out by a qualified person, eg. a Gas Safe registered engineer. The gas meter and supply must be sited in accordance with the requirements of BS6400.

### Plant room layout (Refer Fig 2)

When planning the layout of the boiler room, allowance must be made for opening the boiler door, boiler assembling, boiler cleaning and maintenance. The boiler door may be hinged from the right (as illustrated) or the left. A ceiling height of at least 2.3m is recommended. Wall clearances are:

- W1 - at least 700mm.
- W2 - burner length A + 100mm.
- W3 - 1000mm (in front of boiler for cleaning).
- W4 - 500mm minimum (behind boiler for cleaning).

### Plinth dimensions (Refer Fig 3)

Plinth height - at least 50mm, smooth and level.

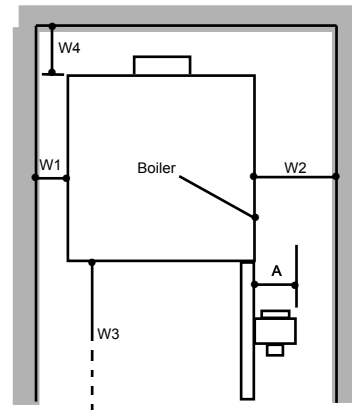

Fig 2 - Wall clearances

Boiler	L1 mm
CKON -05	1170
CKON-06	1315
CKON-07	1460
CKON-08	1605
CKON-09	1750
CKON-10	1890
CKON-11	2035

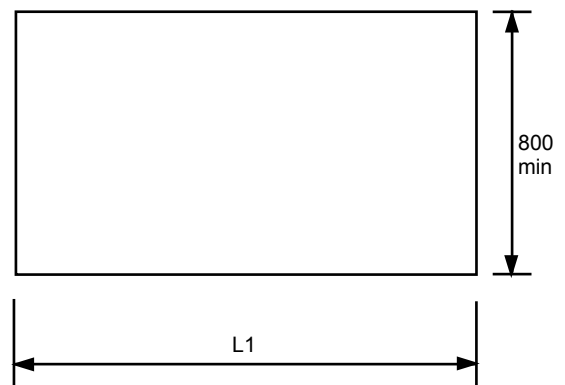

Fig 3 - Plinth dimensions

# Installation requirements

## Air supply

Air for ventilation and combustion must be provided for gas fired boilers in accordance with either BS 6644:2005 or IGEM/UP/10. Air supply for oil fired boilers must conform to BS 5410 : Part 2.

## Chimney design

The CKON boiler is designed to operate with a pressurised combustion chamber and the chimney is not required to assist the burner in overcoming the boiler resistance. The chimney must cater for the total internal resistance of the flue system from each boiler outlet and not impose an additional load on the burner.

## Water circulation (Refer Fig 4)

The flow water temperature from the boiler must reach 60°C (gas firing) or 50°C (oil firing) within 10 minutes of the boiler being brought into operation. Thereafter, water circulation should be maintained through the boiler such that the boiler flow water temperature is always above 60°C (gas firing) or 50°C (oil firing). A pump overrun facility is necessary to ensure that water circulation is maintained for at least three minutes after the boiler is switched off.

There are several ways of providing boiler protection, eg shunt pumps, primary loops, etc. A typical boiler pump and 3-port valve arrangement is shown in Fig 4a and b.

For multi-boiler systems a 'reverse return' pipework configuration is required to ensure equal distribution of water flow through the boilers.

## Water treatment

Whenever a new boiler is connected to an existing system, the pipework must be thoroughly cleaned and flushed. Clyde recommend that a permanent means of filtration be fitted into the return pipework, such as a sludge trap, hydrocyclone or full flow duplex filters. The boiler guarantee will be invalid if waterways are blocked by debris or carbonate deposits. Long term water treatment is essential to the economic operation and life of both new and refurbished heating systems.

For full information on cleaning, flushing and protecting hot water systems, refer to BSRIA Application Guide AG 1/2001.

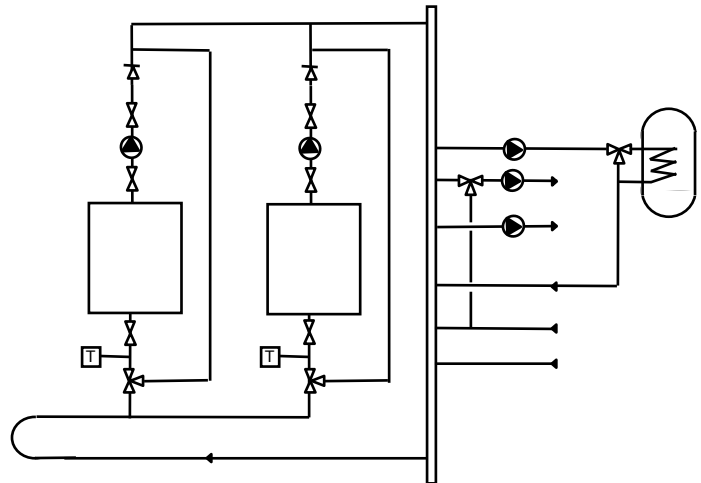

Fig 4a Multiple boilers with individual pumps

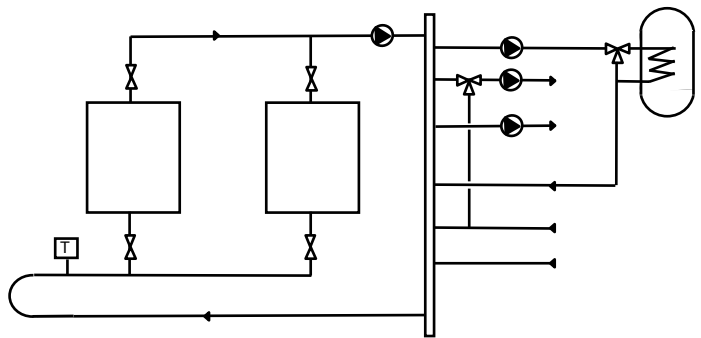

Fig 4b Alternative arrangement for boiler protection with a primary loop

## Electrical supply (Refer Fig 5)

A 400V 3PH supply is required for some of the standard burners offered, and the connection details are shown opposite. The boiler control panel requires an additional 230V 1PH supply.

If a 230V 1PH burner is being used, the fused supply (max 15A) should be taken to the control panel only. The harness and connector supplied by Clyde will feed the burner.

The electricity supplies to the burner and boiler control panel must be wired in accordance with IEE Regulations. A separate supply and isolating switch is required for each boiler in the plant room.

All isolating switches and fuses must be provided by the installer. Burner start/run currents for fuse specification are available on request. Burner wiring diagrams and technical data are also available on request.

All connections between the boiler control panel and the burner are made through harnesses with matching plugs and sockets, supplied as standard.

**Note:** Fig 5 is only diagrammatic. Double pole switches with the required minimum separation must always be used.

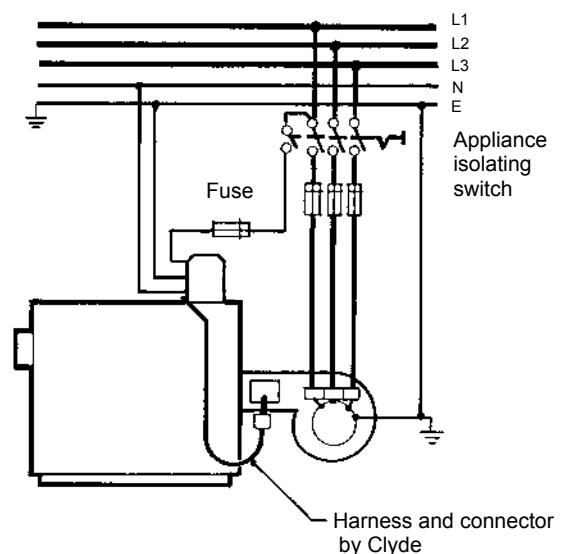

Fig 5 - Electricity supply

## Installation requirements

---

### Flow and return water connections

The cast iron connection pieces are shown in Figs 6a and 6b below. The return connection incorporates a water turbulator that eliminates the need for a sparge pipe in the boiler return. There is an R1 BSP tapping in each connection for use as a boiler drain point and can also be used for shunt pump connection (if required).

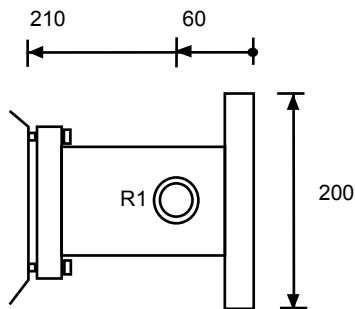

Fig 6a Flow water connection

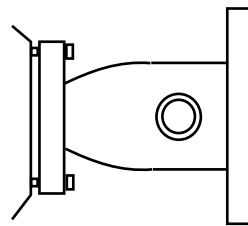

Fig 6b Return water connection

---

## Boiler control panel and wiring

Control panel CKCR2 provides 2-stage burner control for high/low operation whilst panel CKCR1 provides 1-stage burner control for on/off, modulating or LFS operation. Thermostat TR is a 1-stage item with CKCR1 and a dual thermostat (1 and 2 stage) with CKCR2.

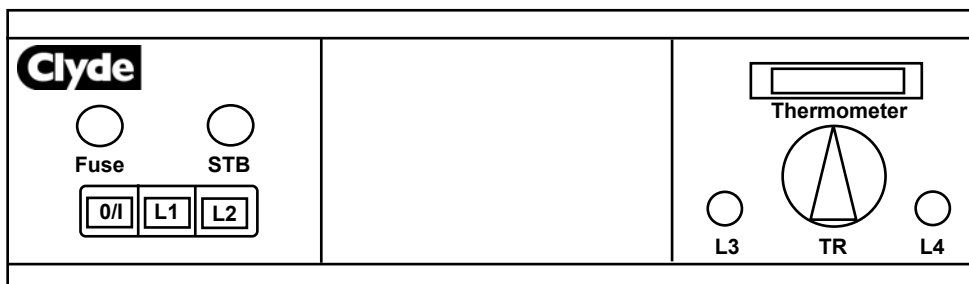

Fig 7 Boiler control panel

# Boiler control panel and wiring

## Key to figs 7 and 8

- EC1 Energy Control 1
- L1 On/off indicator lamp
- L2 Boiler high limit lock-out lamp (lamp is illuminated when running and goes off in lock-out conditions)
- L3 Stage 1 run lamp
- L4 Stage 2 run lamp
- STB High limit thermostat (factory set)
- TR Boiler thermostat (1-stage for CKCR1 or dual operation [TR and TR2] for CKCR2)

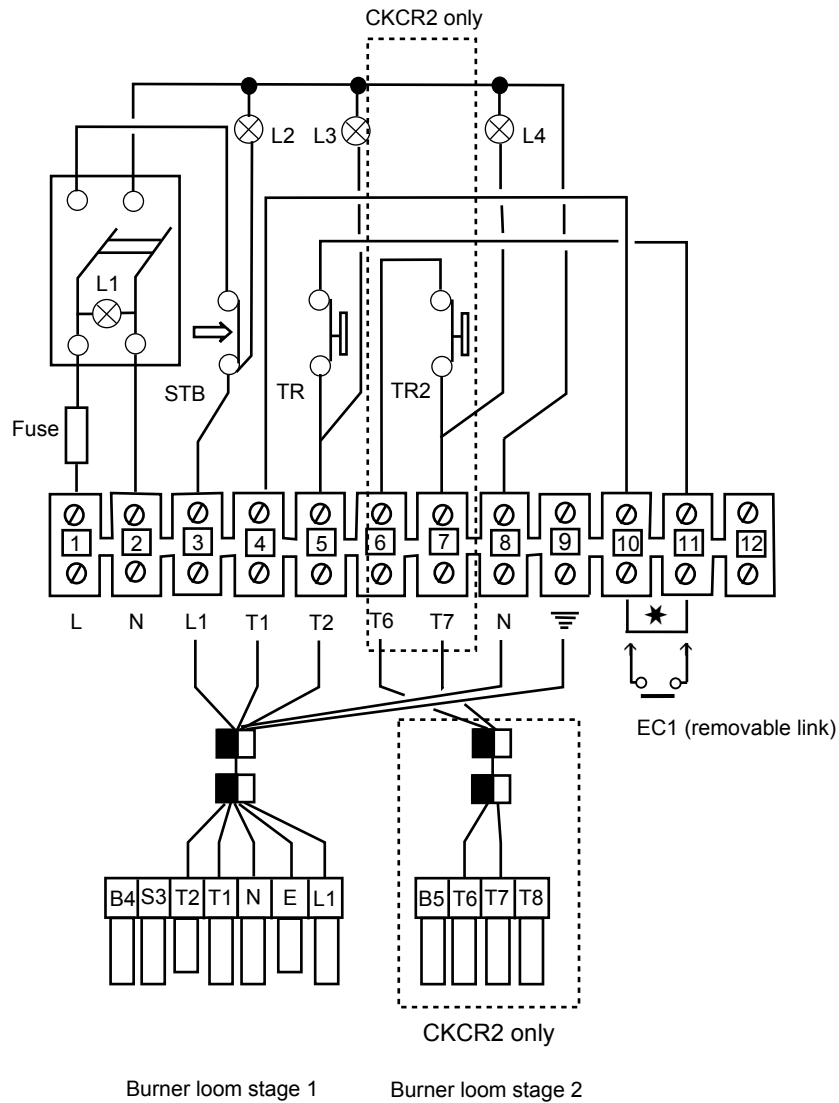

Fig 8 Boiler control panel wiring

This publication is issued subject to alteration or withdrawal without notice. The illustrations and specifications are not binding in detail. All offers and sales are subject to the Company's current terms and conditions of sale, a copy of which is available on request.

---

**Clyde Energy Solutions Ltd**

Units 13 - 14 Charlwoods Rd  
East Grinstead  
West Sussex RH19 2HU  
t : 01342 305550  
f : 01342 305560  
e : [info@clyde4heat.co.uk](mailto:info@clyde4heat.co.uk)  
w : [clyde4heat.co.uk](http://clyde4heat.co.uk)

EDS 803/2  
November 2011